

- wiring labels, 6
- Switching the system on, 9
- Tachometer, 5
- Tell-tales. See Peak values
- Temperatures
 - minimum displayable, 11
 - oil. See Oil temperature. See Oil temperature
 - water. See Water temperature. See Water temperature
- Template for the Display Module, 65
- Tools needed, 34
- Trackside infra-red beacon. See Beacon
- Trip meter
 - display, 10
 - resetting, 36
- Troubleshooting, 54
- units of measurement, 10
- Units of measurement, ii
- Unpacking, 4
- Velcro. See Dual-Lock
- Warning lights
 - additional, 37
 - Warning lights
 - alarms. See Alarm warning light
 - gear shift. See Gear shift warning light
 - installation, 37
 - maximum power, 37
 - Water temperature
 - alarm, 17
 - display, 11, 12
 - water temperature sensor, 41
 - Water temperature sensor
 - installation, 41
 - wiring label, 6
 - Wheel
 - circumference, 30, 31
 - pulses per revolution, 30, 31
 - Wheel speed sensor
 - installation, 42
 - wiring label, 6
 - Wiring harness, 6
 - extenders, 51
 - installation, 51
 - schematic diagram, 67
 - Wiring labels, 6



ST8130 Road Car Display System

**2011 Release
Users Guide**

- delay, 14
- Gate value, 14, 16
- Gear shift warning light, 19
 - wiring label, 6
- Infra-red beacon. See Beacon
- Installing the Display System, 34
- Internal Battery Low message, 15
- Labels on wiring, 6
- Lamps. See Warning lights
- Lap number
 - display, 13
- Lap time, 18
 - display, 12, 13
 - recording manually, 13
 - resetting, 18, 36
- Lap timing sensor
 - installation, 49
 - wiring label, 6
 - menu items, 21
- MSS connector, 46
 - multi-stage shift light, configuration, 25
- Odometer
 - display, 10
- Oil pressure
 - alarm, 17
 - display, 11
- Oil pressure sensor
 - wiring label, 6
- Oil temperature
 - alarm, 17
 - display, 11
 - oil temperature sensor, 41
- Oil temperature sensor
 - installation, 41
 - wiring label, 6
- Operating the system, 9
- Peak values, 14
 - displaying, 14, 36
 - resetting, 15, 36
- Peak Values
 - memory, 15
- Performance parameters, 1
- points connection, 38
- power supply, 7
- Power supply, 6
- Pressure sensors, 39, 40
- Pulse amplifier
 - adjustment, 47
 - connection, 46
 - installation, 44
 - specifications, 48
- Redisplaying last alarm, 18
- Resetting peak values, 15
- resistor connection to coil, 38
- RPM Gate Value. See Gate Value
- service and support, 69
- service enquiries, 70
- Showing the last alarm, 18
- Speed sensor (ST8130). See Pulse amplifier
- Speed sensor (ST8131). See Wheel speed sensor
- Speedometer, 8
 - change from MPH to km/h, 36
 - display, 10
- ST492. See Pulse amplifier
- ST8130 components, 4
- ST8131 components, 5
- Stack contact details, 73
- Stack web-site, 69
- Switches
 - functions - normal operation, 36
 - installation, 36
 - summary of functions, 68

Index

- Alarm warning light
 - external, 37
 - wiring label, 6
 - alarms, 16
- Alarms
 - battery voltage, 17
 - clearing, 9, 18, 36
 - fuel level, 17
 - fuel pressure, 17
 - oil pressure, 17
 - oil temperature, 17
 - redisplaying, 18
 - showing last, 18
 - start-up, 7
 - switching on or off, 20
 - water temperature, 17
- Amplifier. See Pulse amplifier
- Analogue tachometer, 5
- Battery voltage
 - alarm, 17
- Beacon, 50
 - battery condition lamp, 51
 - power supply, 51
- Calibration
 - fuel level, 26
 - wheel speed (ST8130), 31
 - wheel speed (ST8131), 30
- Clearing an alarm, 18
- Configuring the display system, 20
 - switches to enter
 - configuration mode, 36
 - configuring the multi-stage shift
 - light, 25
 - contact breaker connection, 38
 - contacting your dealer, 69
 - Custom configured ST8130, 34
 - Datalogging subsystem
 - wiring label, 6
 - Digital display panel, 5
 - Dimensions, 35
 - Display
 - backlighting, 9
 - Display layers, 9
 - changing layer, 36
 - layer 1, 10
 - layer 2, 11
 - layer 3, 11, 12
 - layer 5, 12, 13
 - Display module, 5
 - dimensions, 35
 - positioning, 35
 - template, 65
 - Dual-Lock, 45
 - electronic ignition), 38
 - engine management unit), 38
 - Engine speed (RPM), 37
 - Engine speed (RPM), wiring label, 6
 - External warning lights. See Warning lights
 - Fitting the display module, 35
 - frequently asked questions, 69
 - Fuel level
 - alarm, 17
 - calibration, 26
 - display, 10
 - Fuel Level
 - calibration Table, 30
 - Fuel level sensor
 - wiring label, 6
 - Fuel pressure
 - alarm, 17
 - display, 12
 - Fuel tank sender Installation, 48
 - Gate value, 15

Preface

Congratulations

Congratulations on choosing one of the models from the Stack ST8130 Road Car Display System. This series contains three models:

1. The ST8130 System. This system is supplied with a ST670 wheel speed sensor which obtains information about the vehicle's speed directly from one of its wheels. If the ST670 is not suitable, an optional ST492 pulse amplifier can be selected at time of ordering. This obtains speed information from the vehicle's original equipment transmission sensor.
2. The ST8130P System. In addition to the ST8130 this system includes a Fuel Pressure sensor.
3. The ST8130M System. In addition to the ST8130P standard features this system is supplied with the Stack Predictive Lap timing system.

Each system will give you a wealth of information to enable you to obtain the maximum safe performance from your vehicle.

Purpose of this manual

This manual will help you install and use either model in the Stack ST8130 Road Car Display System. It explains how to set up and configure the system for your vehicle.

Edition Notice

This edition is for all versions of the ST8130 Road Car Display System distributed to customers worldwide. The units of measurement used to illustrate the use of the display systems in this edition are for the UK version. Units used in the various versions are shown in the following table:

Parameter	UK	US	EC
Speed*	MPH or km/h	MPH or km/h	km/h or MPH
Distance*	Miles or km	Miles or km	km or Miles
Temperature	Degrees C	Degrees F	Degrees C
Wheel Circ.	Millimetres	Inches	Millimetres
Pressure	PSI	PSI	Bar

* Speed and distance units can be changed at any time by pressing Switches 1 & 3 together.

- Once we have confirmation that payment has been received for this service, the goods will be returned to you.

Cost and Duration of Service

All service and repair work is conducted at Stack's factory in the UK. Both the cost and the duration of the service will depend on:

- Your Geographical location.
- Whether the goods are covered by a warranty.
- The complexity of the repair work required once the initial inspection has been completed.

Cost and Duration of Inspection – Your dealer will be able to advise on the cost of the initial inspection work. As stated above it is your responsibility to arrange for the safe shipment of the goods.

The time required to complete any service or repair work is dependent on the outcome of the initial inspection. At the time of receiving your RAN form, we will provide an estimated delivery time, which is subject to the outcome of the initial inspection.

Priority Service – If you require your goods to be returned faster than the estimated delivery time, we can offer a priority service, for which there will be an extra charge. Again, the time required to complete any service or repair work is dependent on the outcome of the initial inspection. Wherever possible we will return the goods within our priority delivery times:

- UK - 2-3 working days
- USA & Rest of World (RoW) - 7 working days

4. Once we have confirmation that payment has been received for this service, the goods will be returned to you.

Cost and Duration of Service

All service and repair work is conducted at Stack's factory in the UK. Both the cost and the duration of the service will depend on:

- Your Geographical location.
- Whether the goods are covered by a warranty.
- The complexity of the repair work required once the initial inspection has been completed.

Cost and Duration of Inspection – Your dealer will be able to advise on the cost of the initial inspection work. As stated above it is your responsibility to arrange for the safe shipment of the goods.

The time required to complete any service or repair work is dependent on the outcome of the initial inspection. At the time of receiving your RAN form, we will provide an estimated delivery time, which is subject to the outcome of the initial inspection.

Priority Service – If you require your goods to be returned faster than the estimated delivery time, we can offer a priority service, for which there will be an extra charge. Again, the time required to complete any service or repair work is dependent on the outcome of the initial inspection. Wherever possible we will return the goods within our priority delivery times:

- UK - 2-3 working days
- USA & Rest of World (RoW) - 7 working days

Related Products From Stack Limited

If you need information about other Stack motor sport products, these can be obtained from Stack or from your local Stack dealer. Products available from Stack include:

- Harsh Environment Digital Video Recorders (DVR)
- Display and Data Logging Systems
- Display and Analysis Software
- Intelligent Tachometers
- Action Replay Tachometers
- Performance Analysers
- Speedometers
- Boost Gauges
- Analogue Sensors
- Digital Sensors
- Radio Telemetry Systems

Stack ® is a registered trademark of Stack Limited. Information in this publication is subject to change without notice and does not represent a commitment on the part of Stack Limited. No responsibility is accepted for error or omission. Copyright © 2011 Stack Limited

Contents

Preface.....i

Contentsiv

Chapter 1. Introducing the Display System.....1

 ST8130 Models.....2

 How to use this Manual3

Chapter 2. Getting Started4

 The Display Module5

 Wiring Harness6

 Connecting the Components.....7

Chapter 3. Operating the Display System9

 Switching the Display System on9

 Changing the display layers9

 Peak Values (Tell Tales).....14

 Alarms.....16

 Lap times18

 Gear shift light19

Chapter 4. Configuring the Display System20

 Configuration mode20

 Configuring the Multi-Stage Shift Light.....25

 Calibrating the Fuel Level26

 Wheel Pulses and Circumferences.....30

Chapter 5. Installing the Display System.....34

 Who can install the Display System?34

 Tools needed to install the Display System34

 Preconfigured Display Systems34

 Custom Configured Display Systems34

 Fitting the Display Module35

 Switches36

 Warning lights.....37

 Engine Speed (RPM) Measurement37

 Oil Pressure sensor39

 Fuel Pressure sensor40

 Oil and Water Temperature Sensors.....41

 Wheel speed sensor (ST670-Option).....42

ensure that the goods are adequately packaged and insured for the journey.

To arrange for your equipment to be returned for an initial inspection, please contact your dealer. The process for returning goods is as follows:

1. Contact the dealer from whom you purchased the goods.
2. Your dealer will complete and send you a Returns Authorisation form by fax or mail. This form includes a unique Returns Authorisation Number (RAN).
3. You must include that form with the goods when shipped. Your dealer will be able to advise you on the shipping of your goods.
4. At the time of shipping your goods you should arrange to make payment via your dealer for the initial inspection. Your dealer will advise you of this fee.

Your goods will then be returned to Stack’s factory in the UK. The inspection and service process is explained below:

1. On receipt of your goods they will undergo the initial inspection by one of our engineers.
2. Our engineers will attempt to reproduce the fault as reported and an assessment will be made with regards the complexity of the corrective action:
 - i) If the corrective action can be identified at this stage, we will contact you with details of the repair work required, as well as a quotation for that work.
 - ii) If corrective action cannot be easily identified at this stage, a full diagnosis and a “Corrective Action Assessment” will be conducted. Using this information we can then contact you and advise on the next course of action and will quote on expected duration and cost of repairs where applicable.
3. Once we have received your authorisation to proceed with any repair work required, we will complete the work and request payment. A full final test will be conducted before the goods are packed ready for shipping.

When contacting your Dealer with a Technical Support or Service enquiry it is important that you have to hand the following information:

- Serial Number (found on the rear of the product).
- The Model Number.
- The date of purchase.
- A copy of the packing list supplied with the product.
- If it is a Data Logging product, please provide the TAG number and the software licence number. Your Dealer will be able to advise you if you need help in locating those numbers.

This information will help your Dealer ensure that your enquiry is handled and processed in an efficient manner.

Pulse Amplifier Interface (ST492-Option)	44
Fuel Tank Sender	48
Lap timing sensor (Optional, Std on ST8130M)	49
Trackside Infra-Red Lap Beacon (Optional, Std on ST8130M)	50
Wiring harness	51
Checks and Alarms	53
Chapter 6. Troubleshooting	54
Appendix A. Template for the Display Module	65
Appendix B. Wiring Harness Diagram	67
Appendix C. Summary of Switch Functions	68
Appendix D. Service and Support	69
Stack Contact Details	73
Index	74

Appendix C. Summary of Switch Functions

At Stack we pride ourselves on having, not only a very highquality engineered product range, we also strive to offer a first class service when it comes to supporting our customers and installed product base.

Stack Web-site

If you have a question about a Stack product or if you are experiencing a problem, we have made a wealth of information available on our web-sites where you can find the answers you need.

International

www.stackltd.com

United States

www.stackinc.com

Frequently Asked Questions

Log-on to the Stack web-site, click on **Motorsport Division** and then the **Support tab** at the top of the home page. Then click on the **FAQ Page** item.

If you need a User Guide click on the **Manuals and Download Support Area** item. You will be asked to submit some basic information for Stack's internal use but, once submitted, you will have immediate access to downloadable versions of our product manuals. These manuals will give clear instructions on the installation and correct operation of your Stack product as well as including useful Troubleshooting sections.

If you still have unanswered questions then please contact the **Dealer** from whom you purchased the product.

Contacting your Dealer

For a current list of dealers log-on to the Stack web-site, click on Motorsport Division and then the Where to buy tab at the top of the home page and select the Distributors menu item.

Appendix C. Summary of Switch Functions

Normal Operation

Switch(es)	Functions
Switch 1	Show the peak values
Switch 2	Clear Alarm or Show Last Alarm
Switch 3	Clear Alarm or Change Display Layer
Switch 4	Reset the trip distance to zero and start the lap timer. The trip distance is reset after each lap.
Switches 1 & 2 together	Put system into configuration mode.
Switches 1 & 3 together	Change speed units between MPH or km/h (UK version only).
Switches 1 & 4 together	Reset the peak values and lap times.

System Configuration Mode

Switch(es)	Functions
Switch 1	Show the peak values
Switch 2	Clear Alarm or Show Last Alarm
Switches 1 & 2 together	Enable or disable an alarm for the parameter being displayed
Switch 3	Display the next configurable parameter
Switches 1 & 2 together	Enter Fuel Calibration mode (when applicable)
Switch 4	Exit configuration mode and return to normal operation mode

Chapter 1. Introducing the Display System

The models in the Stack ST8130 Road Car Display System monitor and display a range of values, known as performance parameters, needed for effective car and driver management in most driving situations. The models in the ST8130 Series are the ST8130, ST8130P and the ST8130M.

The models combine an analogue tachometer with a digital display for the following performance parameters:

1. Engine speed (RPM)
2. Wheel speed
3. Oil pressure
4. Oil temperature
5. Water temperature
6. Fuel pressure (optional on ST8130 variant)
7. Fuel level
8. Battery Voltage
9. Lap times (last completed and best) (lap time sensor standard on ST8130M variant)

You can view the peak values (tell-tales) for all the parameters.

All systems provide an alarm light to alert the driver that a warning condition has been detected. The warning conditions are based on preset alarm values for the following performance parameters:

1. Low oil pressure
2. High oil temperature
3. High water temperature
4. Low fuel pressure

5. Fuel level.

The fuel level alarm is indicated by a separate warning light; the unit does not display any message for the fuel level alarm.

6. Battery voltage

When the warning condition alarm light is switched on, a warning message is shown on the digital display to identify the condition. You can enable or disable the warning system for each parameter individually.

You can cancel the warning message by pressing a switch. Doing this does not turn off the warning condition alarm light, which stays on until the condition no longer applies.

You can redefine the preset alarm values for each parameter to those which are more suitable for your vehicle.

The system provides outputs for two external warning lights:

- a gear shift warning light that is based on an RPM value that you define for your vehicle
- an additional alarm warning light for the alarms described above

Either model can also be fitted with an optional lap timing sensor.

ST8130 Models

Standard ST670 wheel speed sensor. This system obtains the vehicle speed from the rotations of one of the wheels on the vehicle.

Optional ST492 pulse amplifier. This system obtains the vehicle's speed from pulses generated by the vehicle's original equipment gearbox or transmission sensor.

Appendix B. Wiring Harness Diagram

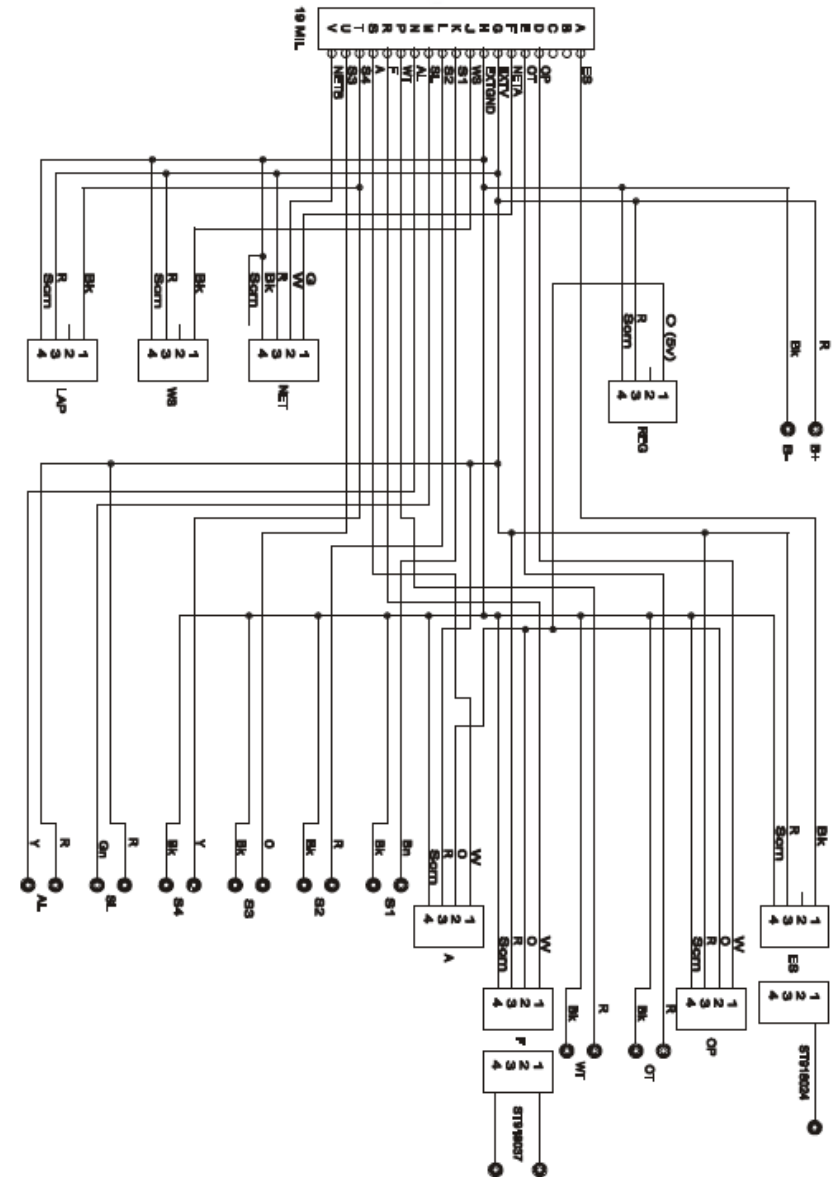

How to use this Manual

Stack recommends that you unpack and connect the components in the system before you install it in your vehicle. This will enable you to familiarise yourself with operating the display and configuring it for the vehicle in which you intend to install it.

This manual starts by taking you through the process of setting up the system before installation, operating the digital display, configuring the system, setting the alarm values and installing it in the vehicle. By the end of Chapter 2, you will have set up the system so that you will be assured that it is functioning normally. You can then read Chapter 3 and practice using its functions. Chapter 4 takes you through configuring it for your vehicle. Chapter 5 explains how to install it in the vehicle. Chapter 6 provides a set of troubleshooting guidelines.

A full size template for the dashboard cut-out for the ST8130 systems is provided in Appendix A along with a dimensional drawing on page 33. There is a schematic diagram of the wiring harness in Appendix B.

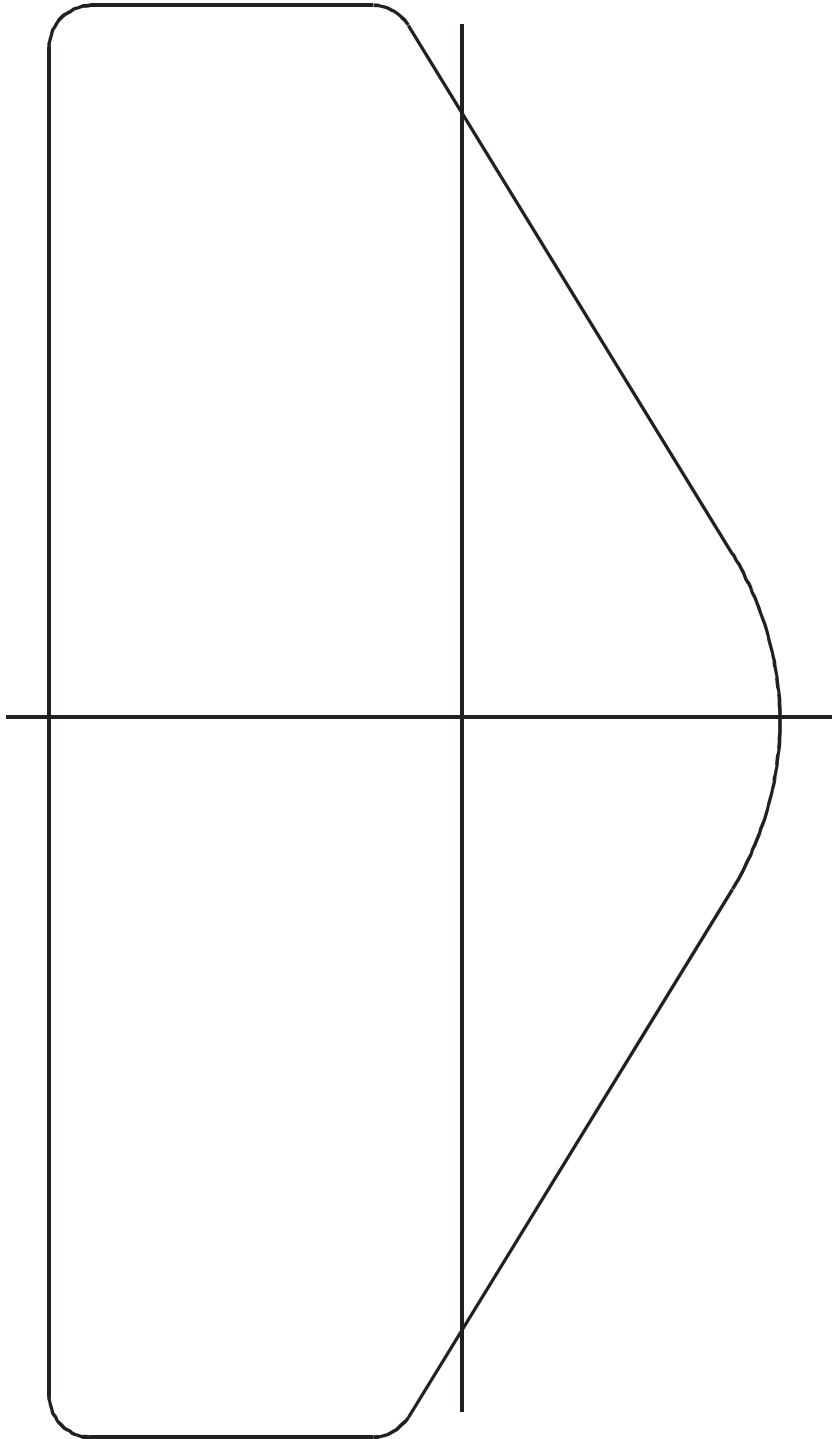

Chapter 2. Getting Started

This chapter guides you through the initial unpacking and setting up of the equipment for pre-installation checks and familiarisation with its operation.

Standard ST8130 Display System Items

The ST8130 Road Car Display System is supplied with the following standard components:

Quantity	Description
1	Display Module (ST867) with 2 mounting brackets
1	Wiring Harness (ST872)
1	Fuel level Extender (ST918037)
1	Oil Pressure Sensor (ST747-M10 (EU) or ST747-1/8 NPTF (UK/USA)
1	Fuel Pressure Sensor (ST747-M10 (EU) or ST747-1/8 NPTF (UK/USA) and 1.4Mtr extender (ST918021) (optional on ST8130)
2	Oil & Water Temperature Sensors (ST762 (EU) ST764 (UK/USA)
4	Switches (supplied with and to be connected to the wiring harness)
1	Speed Sensor (ST670) (standard) or Pulse Amplifier (ST492) (optional)

Optional ST8130 Display System Items

The ST8130 Road Car Display System can be used with the following optional components:

Quantity	Description
1 or	5 LED Multi-Stage Gear Shift Warning Lamp (ST539) External Gear Shift Warning Lamp (ST534 or ST537) and (ST918081) adapter cable

Appendix A. Template for the Display Module

Use the template on the following page for cutting out an aperture for the Display System.

Optional Lap Timing Items (included with ST8130M systems)

The lap timing system consists of the following components:

Quantity	Description
1	Infra-red Lap Beacon (ST544)
1	Lap Timing Receiver (ST543)

The Display Module

The Display Module consists of an analogue tachometer, two indicator lights and a digital display panel.

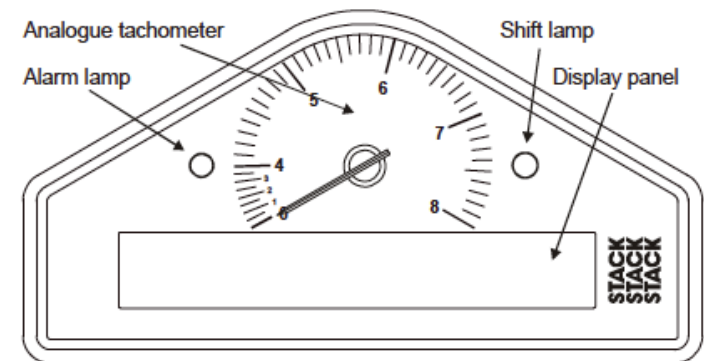

Front View

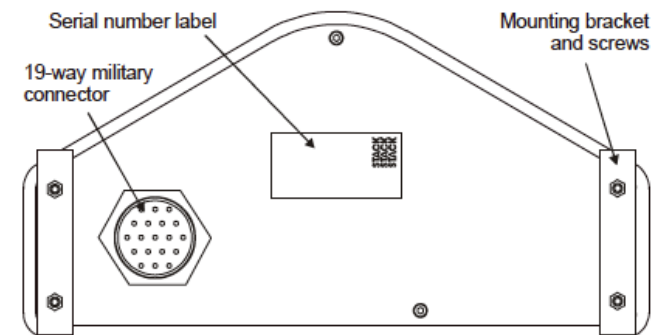

Rear View

Wiring Harness

The Display Module is connected to a variety of sensors by a wiring harness. The wiring harness has a 19-way military connector for connection to the Display Module. Each of the wires in the harness is labelled.

Label	Connection to
S1 to S4	Switches 1 to 4
WS	Wheel speed input (ST492 or ST670)
SL	Gear shift warning light
AL	Alarm warning light
NET	Data logging expansion pack
LAP	Optional lap timing sensor (Std on ST8130M)
A	Fuel pressure sensor (optional on ST8130)
ES	Engine speed (RPM)
OT	Oil temperature sensor
WT	Water temperature sensor
OP	Oil pressure sensor
F	Fuel level sensor
B+	12v Supply (Battery)
B-	Battery negative

Symptom	Cause	Remedy	Notes
Fuel level reading does not change	Fuel sender wiring not connected correctly Faulty fuel sender Fuel sender not suitable for use with ST8130 Display System	Check wiring Check fuel sender Check with your Stack dealer for suitable alternative	If there is no reading from the fuel sender, remove the fuel sender unit from the tank, earth it to the vehicle with a clip lead and move it by hand to verify that the
	Fuel sender not calibrated	See Chapter 4 for information on how to calibrate the fuel sender.	V oltage reading on the red lead changes. The voltage on the red lead should range from 0V to 5V.
Lap time is not displayed automatically when lap marker receiver is fitted	Lap marker receiver lead faulty	Check lap marker wiring	Press lap switch 4. If display changes, replace receiver after checking its wiring.
	Lap marker receiver faulty	Replace lap marker receiver	
The display unit functions correctly until the engine is started whereupon the digital display either freezes or flashes. The display functions correctly as soon as the engine is stopped.	High levels of electrical interference	Fit suppressors to the high tension leads. Use silicon resistive leads	

Symptom	Cause	Remedy	Notes
	Pulse amplifier not connected Pulse amplifier out of adjustment	Rotate wheels and check the LED on the ST492 for pulse signals	ST492 option
Speed reading dies after a short time	Ambient temperature too high	Shield the sensor from radiated heat from brakes and bearings. Insulate sensor from conducted heat with fibre washers. Duct cooling air around the sensor	Maximum temperature for correct operation of the wheel speed sensor is +80°C (175°F)
No alarms for water, oil or fuel (temperatures and pressures) being displayed	All the alarms have been switched off	Switch on the required alarms	Alarms only operate when the engine is running above the RPM gate value.
	The engine RPM gate value is set too high	Reset the RPM gate to a lower value.	
Display and alarm light flash when the engine is running	Intermittent alarm caused by a parameter with its alarm level set too close to the normal operating value	Either change the value for the alarm or turn the alarm off	Press Switch 2 to see which sensor is causing the alarm

Wiring Harness

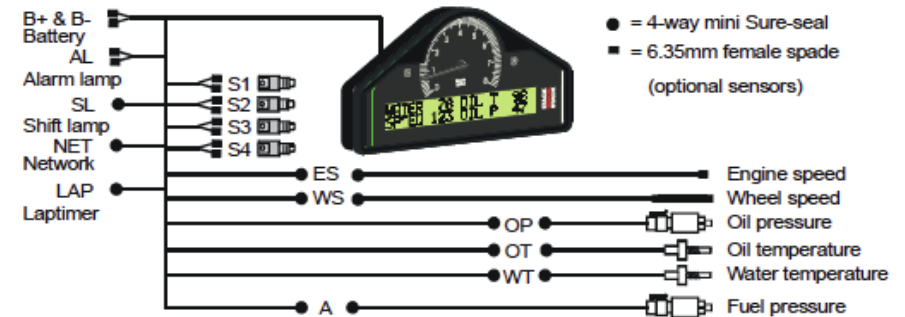

Refer to the diagram above:-

1. Connect the wiring harness to the display module.
2. Connect the four switches to the cables labelled S1 to S4.
3. Connect each of the sensors that you have purchased to the appropriate wire in the wiring harness, as shown above.
4. Connect a 12v DC power supply to the power input cable, eg, from a car battery. Use 5 Amp fuse in the wire to the B+ connector.
5. Switch on the 12v DC power supply.

The Display Module should start up with an alarm signal indicating low oil pressure which is normal in this environment.

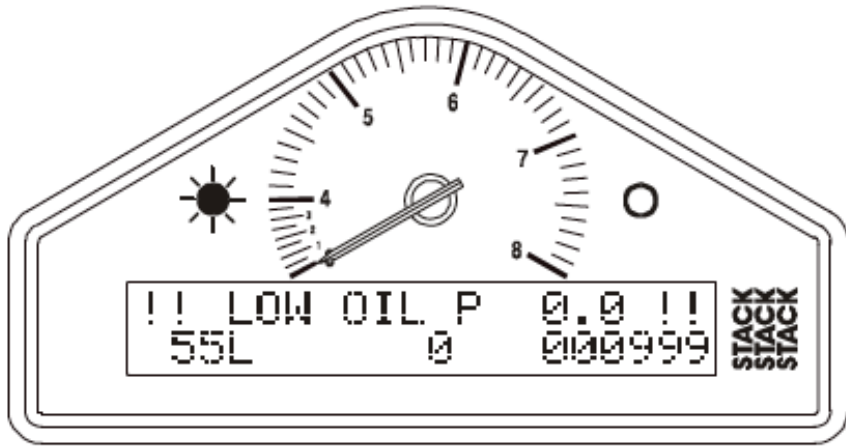

- ! Whenever a warning message is shown on the top line of the digital display, the speed of the vehicle always continues to be shown in the centre of the bottom line.

You can now proceed to familiarise yourself with operating the Display Module.

Symptom	Cause	Remedy	Notes
Tachometer reading erratic, pointer jumps high or low	Incorrect wiring	Reconnect the tachometer as specified in manual	
	Signal from ignition system or coil is noisy	Condition the ES signal by placing a resistor in line with the ES wire	Resistor values: 10K ohms for dedicated tacho output; 47K Ohms for coil connection (Non-CDI); 100K Ohms for coil connection (CDI). Resistors ½W 5% 350v
Displayed speed value too high or too low by a constant %-age amount.	System configured with wrong number of targets per wheel revolution	Reconfigure the system with correct values	
	System configured with wrong circumference.		
No speed reading Speed reading erratic, value jumps high or low	Faulty sensor and/or wiring	Check sensor indicator for correct operation	Rotate the wheel by hand and check that the sensor indicator lights up as each target passes the sensor
	Incorrect sensor gap (too far or too close)	Check that the gap is approximately 1mm / 40thou	ST670 option
	Sensor and targets moving apart	Fabricate a more rigid sensor bracket	

Symptom	Cause	Remedy	Notes
Display values and messages unclear or unreadable (poor contrast)	Display too hot or too cold	Ensure that the display is operated within the specified temperature range	Operating temperature is -20°C ($+5^{\circ}\text{F}$) to $+70^{\circ}\text{C}$ ($+158^{\circ}\text{F}$)
	ECU interface shorted (if fitted)	Check the two core screen ECU wires for short circuits	ECU wire is 300mm / 12" inside the main sensor leads sleeve. Make sure that none of the wire ends are shorted
No RPM speed reading	Incorrect wiring	Check the connection of the engine speed wire to the ignition system (or sensor, if used)	See instructions supplied in this manual. If connected directly to the coil, check that it is to the switched low tension side (usually the negative side).
Displayed RPM value too high or too low by a constant %-age amount.	System configured with wrong number of engine cylinders.	Reconfigure system to correct number of cylinders.	Ignition systems may either: Produce "waste" sparks giving double the number of cylinders per revolution or Use multiple coils where each additional coil gives proportionately fewer pulses per revolution.
	Ignition system pulses per revolution not same as number of cylinders	Reconfigure system to correct number of pulses per revolution.	

Chapter 3. Operating the Display System

This chapter takes you through the operation of the system so that you can familiarise yourself with its use before you install it in the vehicle.

Switching the Display System on

You will have switched the system on already if you have followed the instructions in the previous chapter and have just set the system up for the first time before installing it. When installed in the vehicle, the system is switched on when you switch the ignition on.

When the power is first switched on, the digital display will immediately show a "Low Oil P" warning and the alarm light will come on. The tachometer will reset itself by moving the needle until it touches the stop-pin and then moving it back to the zero RPM position. Press Switch 3 to clear the warning message from the display. (Switch 2 can also be used for this.)

The digital display panel and the analogue dial face are always backlit when the system is switched on. If none of these actions occurs when you switch on, switch off the power to the system and consult the section on troubleshooting in this manual.

Changing the display layers

The digital display has five display layers. Each display layer shows three parameters and their values. Each of the display layers is displayed in turn by pressing switch 3. Press switch 3 when display layer 5 is being displayed in order to return to display layer 1.

- ! The format of the values in these displays will vary for systems supplied outside the UK, as the parameters are displayed in different units.

Display Layer 1

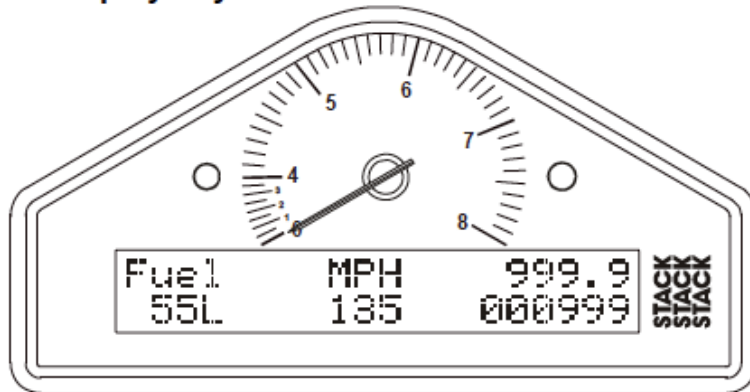

Display layer 1 shows:

- Fuel level (Note that when the amount of fuel in the tank is changed the displayed value changes slowly, about 1 litre every 5 seconds, to minimise the effects of fuel surge).
- Current speed (MPH or km/h)
- Trip indicator (miles or km)
- Odometer (miles or km)

Press Switch 3 to change the display to layer 2.

Symptom	Cause	Remedy	Notes
	Faulty switch wiring	Check switch wiring for correct continuity	Pin U to yellow S4 wire less than 1.0 Ohm and Pin U to Pin H (earth) greater than 1M Ohms)
External warning light dead when the display warning light is OK	Bulb has burnt out	Replace bulb	Swap with the other light to confirm burntout bulb. If not burnt out, check wiring.
	Faulty wiring to light	Check continuity of wiring.	
	Driver circuitry burnt out	Return unit	Swap with the other light to confirm burntout bulb. If not, check wiring
External gear shift light dead	Bulb has burnt out	Replace bulb	Swap with the other light to confirm burntout bulb. If not, check wiring
	Faulty wiring to light	Check continuity of wiring:	Pin G to red SL wire less than 1.0 Ohm and Pin M to green SL wire less than 1.0 Ohm

Symptom	Cause	Remedy	Notes
Switch 2: Show last alarm function does not work	Switch 2 faulty	Replace switch	Disconnect switch and short its leads. If display changes, replace Switch 2. Otherwise check wiring.
	Faulty switch wiring	Check switch wiring for correct continuity	Pin L to red S2 wire less than 1.0 Ohm and Pin L to Pin H (earth) greater than 1M Ohms)
Switch 3: Change display layer function does not work	Switch 3 faulty	Replace switch	Disconnect switch and short its leads. If display changes, replace Switch 3. Otherwise check wiring.
	Faulty switch wiring	Check switch wiring for correct continuity	Pin U to orange S3 wire less than 1.0 Ohm and Pin U to Pin H (earth) greater than 1M Ohms)
Switch 4 does not reset the trip value back to zero	Lap Marker Receiver triggered	Turn off Beacon	
	Switch 4 faulty	Replace switch	Disconnect the switch and short the leads together. If the display changes replace Switch 4. Otherwise check wiring.

Display Layer 2

Oil T	MPH	Oil P
110 C	135	90.3

Display layer 2 shows:

- Oil temperature (Oil T)
- Current speed (MPH or km/h)
- Oil pressure (Oil P)

Note that the minimum oil and water temperature for which the display gives a true reading is 12°C or 53°F. The unit displays temperatures that are less than this as 0°C or 32°F.

Display Layer 2 (ST8130M variant)

Water	MPH	Oil P
75 C	135	90.3

ST8130M display layer 2 shows:

- Water temperature
- Current speed (MPH or km/h)
- Oil pressure (Oil P)

Press Switch 3 to change display to layer 3

Display Layer 3

Water	MPH	Oil P
75 C	135	90.3

Display layer 3 shows:

- Water temperature
- Current speed (MPH or km/h)
- Oil pressure (Oil P)

Display Layer 3 (ST8130M variant)

```
Oil T   12.6V   Fuel P
110 C   135     65.7
```

ST8130M display layer 3 shows:

- Oil temperature (Oil T)
- Battery Voltage
- Fuel Pressure (Fuel P)
- Current speed (MPH or km/h)

Press Switch 3 to change the display to layer 4.

Display Layer 4

```
Fuel P   MPH   Batt
65.3     135   12.6V
```

ST8130 display layer 4 shows:

- Fuel Pressure (Fuel P)
- Current speed (MPH or km/h)
- Battery Voltage (Batt)

Display Layer 4 (ST8130M variant)

```
Lap 12   MPH   1:35.06
Best 9    135   1:34.10
```

ST8130M display layer 4 shows:

- Current speed (MPH or km/h)
- Latest lap number and its time
- Fastest lap number and its time

Press Switch 3 to change the display to layer 5.

Symptom	Cause	Remedy	Notes
All sensors show fixed high values	Switch 1 (Peaks) faulty	Replace switch	Disconnect switch. If values return to normal, replace switch
	Faulty switch wiring	Check switch wiring	Check wiring for short between connector pins K and H (earth)
Displays pressure values too low and temperature values too high	Low Battery voltage	Recharge battery	The system does not give accurate readings when voltage is below 9.0V
Peak values not updated	Gate value set too high	Change Gate RPM in the display configuration menu	Peak values only updated while the engine RPM is greater than the Gate value
	Internal memory battery dead	Return unit to Stack for new battery service	Display shows !! Internal Battery Low !! warning on power up
Switch 1: Show peak values does not work	Switch 1 faulty	Replace switch	Disconnect switch and short its leads. If display changes, replace Switch 1. Otherwise check wiring.
	Faulty switch wiring	Check switch wiring for correct continuity	Pin K to red S1 wire less than 1.0 Ohm and Pin K to Pin H (earth) greater than 1M Ohms

Symptom	Cause	Remedy	Notes
Water or Oil temperature display gives a fixed temperature reading of 0°C or 0°F when the water temperature is either above 12 °C or 55°F	A temperature sensor has failed	Disconnect sensor and short its leads together. If the reading changes, replace the sensor	
Fixed pressure reading of 99.9 PSI or 9.99 Bar	Pressure sensor has failed	Replace sensor	
	Faulty sensor connections	Check continuity of sensor leads for open circuits. See 5 above.	Pin D to the red OP wire, pin R to the red F wire and pin H to both the black OP and F sensor wires
Fixed pressure reading of -9.99 PSI or -99.9 Bar	Pressure sensor has failed	Replace sensor	Disconnect sensor. If reading changes to that in 7 above, replace sensor
	Faulty sensor connections	Check continuity of sensor leads for short circuits	Check the wiring harness for short circuit
Fixed pressure reading of 0.0 PSI or 0.00 Bar or suspected low/slow reading	Pressure sensor has failed	Replace sensor	
	Faulty sensor connections	Check pressure connections	Check plumbing for a blockage (kinks in flexible hoses)

Display Layer 5

Lap 12	MPH	1:35.06
Best 9	135	1:34.10

Display layer 5 shows:

- Current speed (MPH or km/h)
- Latest lap number and its time
- Fastest lap number and its time

Lap time can be recorded manually using Switch 4 or with the optional lap timing kit.

Display Layer 5 (ST8130M variant)

-	><	+
1:19:88	135	00.00

ST8130M display layer 5 shows:

- A graphical comparison of this lap to a previously selected lap
- Running time from start of lap
- Current speed (MPH or km/h)
- A graphical comparison of this lap against the fastest lap. '+' means the vehicle is going faster than the fastest lap and '-' means it is going slower.

Press Switch 3 to change the display back to layer 1.

Peak Values (Tell Tales)

The system can display the peak values (sometimes called 'tell-tales') that have been recorded during a run for all the monitored parameters.

Peak values are updated only when the engine speed has exceeded its "gate value" for RPM for at least one second. This allows the values to stabilise. Blipping the engine may not be enough to update the peak values. The gate value is a predefined RPM value that is used to control when the system updates the peak values. This is to prevent abnormal peak values from being recorded when, for example, the engine is either not running, is idling or is being warmed up.

The system stores either a maximum or a minimum value as the peak value, depending on the parameter, as in the following table:

Parameter	Peak Type	Gated to RPM
Engine Speed (RPM)	Maximum	No
Wheel Speed	Maximum	No
Oil Pressure	Minimum	Yes
Oil Temperature	Maximum	Yes
Water Temperature	Maximum	Yes
Fuel Pressure	Minimum	Yes
Fuel Level	Value at Reset	No
Battery Voltage	Minimum	No

Displaying the Peak Values

Press and hold Switch 1 to show the peak values for the parameters being displayed on the current layer. Release the switch to return to the normal display.

- ! *The displayed peak fuel level is the value that was current when the peak values were last reset. The amount of fuel used since the peak value reset can be determined by subtracting the current value from the peak value.*

Symptom	Cause	Remedy	Notes
The Low Oil P message does NOT appear on power up. The warning light is not turned on.	Pressure sensor has failed	Replace sensor	
	Sensor connections are faulty	Check for continuity on sensor lead	A reading of 999 on the display indicates an open circuit connection (pin D to the red sensor lead and pin H to the black sensor lead)
	Oil pressure alarm disabled	Check that the oil pressure alarm is set on	
Display gives a fixed temperature reading of 999° C or 999° F	Temperature sensor has failed.	Replace sensor	Disconnect sensor. If reading changes to 0, replace sensor
	Faulty sensor connections	Check the continuity of sensor leads: with the sensor disconnected and the display powered up, there should be 6.25V between the sensor leads.	Otherwise check harness for short circuit

Chapter 6. Troubleshooting

Symptom	Cause	Remedy	Notes
Display is dead (no backlight, nothing on display, no green dial lights)	Ignition is off	Turn ignition on	B+ is 19w connector pin G. Battery is dead Recharge or replace battery
	Battery is dead	Recharge or replace battery	
	Power connection to B+ or B- is faulty	Check if battery is connected correctly. Check power lead continuity	
Display is dead (no backlight, nothing on display, green dial lights on but dim) or Low Battery warning on display	Battery is almost dead	Recharge or replace battery	The power lead B- is 19w connector pin H.
	Power connection to B+ or B- is faulty	Check power lead continuity	
Display flashes and dial pointer resets or vibrates	Battery is almost dead	Recharge or replace battery	
	Power connection to B+ or B- is faulty	Check power lead continuity	

Resetting the Peak Values

You can reset all of the peak values manually. All peak values are reset at the same time. If the engine is running at or above its gate value when the peak values are reset, they are set to the current value of each performance parameter. To reset the peak values:

- Press and hold Switch 1 to display the peak values.
- While holding Switch 1, press and hold Switch 4.
- With Switch 4 held down, you will see the display revert to the current values. The new peak values that are stored are those being displayed when you release Switch 4.

If the engine is running below its gate value, the peak values are not reset to the current values but are set to the values in the following table:

Parameter	New Peak Value
Engine RPM	Current value
Wheel speed	Current value
Oil Pressure	99.9 PSI or 9.99 Bar
Oil Temperature	0° C or 0° F
Water Temp	0° C or 0° F
Fuel Pressure	99.9 PSI or 9.99 Bar
Fuel Level	Current value
Battery Voltage	Current value

Peak Value Memory

The peak values are stored in a memory, which is powered by an internal back-up battery. They remain stored in this memory when the external power source is disconnected from the system. The internal battery needs to be changed every 4-5 years. When the power from this battery drops below a safe level, an alarm is triggered and the warning "Internal Battery Low" is displayed.

Alarms

The Display System has built-in warnings to alert the driver when certain parameters either exceed or fall below their alarm values. For example, a warning is signalled if the oil pressure falls below its alarm value or if the oil temperature rises above its alarm value. You can adjust the preset alarm levels when you configure the Display System. See Chapter 4, Configuring the Display System in this manual.

Some of the warnings (see the following table) are triggered only after the engine speed has exceeded its "gate value" for RPM for at least one second. Blipping the engine may not be enough to trigger a warning. The gate value is a predefined RPM value that is used to control when the system is to trigger a warning. This prevents abnormal warnings from being triggered when, for example, the engine is either not running, is idling or is being warmed up. Once the engine has been running above the gated RPM for at least one second, any problems will trigger an immediate warning.

- ! *The oil pressure alarm will come on at power-up until the engine is started and pressure exceeds the threshold set for the alarm.*

Checks and Alarms

You should check the system to ensure that all the sensors are detecting the correct values. You should also run the engine at its operational levels to check that the values displayed by the Display System are accurate. You should then check out the alarm systems to ensure that they are functioning correctly before going out onto the circuit.

Fitting the wiring harness

When fitting the harness on the vehicle, you should observe the following:

- Start by attaching the harness to the Display Module by connecting the 19-way military connector.
- Position the ends of all the wires at the locations of the sensors, lamps and switches to which each is to be connected, but do not connect them yet.
- All wires should be routed as far as possible and not less than 50mm/2" from ignition HT leads and distributor caps and any other sources of high voltages.
- When you pass any wire through a bulkhead or dashboard, fit a cable grommet or gland into the hole so that the edge of the hole cannot chafe the wire.
- Particular care is needed when passing wires through holes in carbon fibre, as the carbon can cut through cables very easily.
- The heatshrink sleeving around the sensor cables can be cut back, if necessary, to enable the sensor cables to go in separate directions earlier. It is recommended that you always leave at least 150mm/6" of heatshrink sleeving to provide additional strain relief for the cable where it enters the 19-way connector.
- Connect the wires when all the sensors are in position and you have secured the wiring harness.

Wiring labels

See Chapter 2 if you need to check the labels used to identify the individual cables in the wiring harness

The Display System has the following built-in alarms:

Parameter	Alarm triggered when:	Gated to RPM
Oil Pressure	Current value drops below the preset value	No
Oil Temperature	Current value exceeds the preset value	Yes
Water Temperature	Current value exceeds the preset value	Yes
Fuel Pressure	Current value drops below the preset value	Yes
Fuel Level (warning light only)	Current value drops below the preset value	No
Battery Voltage	Current value drops below the preset value	No

Displaying an Alarm

When an alarm condition occurs, the built-in red warning light turns on and the digital display gives a warning message to show the type of alarm:

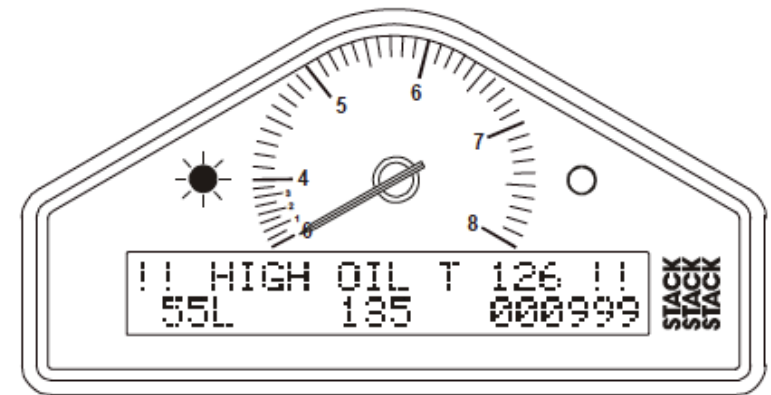

Note that the low fuel warning is indicated by the amber light.

Clearing an Alarm

Press Switch 2 or Switch 3.

Showing the Last Alarm

Press and hold Switch 2.

Lap times

The lap time is displayed for a preset time either when triggered by the infra-red lap time sensor passing the lap time beacon or when the driver presses Switch 4.

You can adjust the preset display time when you configure the Dash-Logger. See Chapter 4, *Configuring the Dash-Logger* in this manual

```
Lap 1:35.06
Best 9 135 1:34.10
```

The most recent lap time is held in display layer 5 (layer 4 for ST8130M). Press Switch 3 to see this display layer. This display gives you time of the last recorded lap and the lap number of the current lap.

```
Lap 12 MPH 1:35.06
Best 9 135 1:34.10
```

Resetting the Lap Time to Zero

Press and hold Switch 1 and then press Switch 4 to reset the lap count and lap time to zero. The lap timer starts recording the time immediately.

```
Lap 0 MPH 0:00.00
Best 0 0 0:00.00
```

Power supply to Trackside beacon

The beacon operates from a 12v DC supply. A sealed leadacid battery with a minimum rating of 2.5 Amp/hour is recommended. This provides about 15 hours of operation. The condition of the battery is indicated by the colour of the LED indicator on the front panel of the unit:

1. Green: Voltage is, at present, adequate for use
2. Red: Voltage is too low (replace the battery)
3. No Colour: Battery exhausted or disconnected

Wiring harness

The Display Module, the sensors, switches and external lights for your Display System are connected together by means of the wiring harness supplied with the system. The wiring harness can be fitted after the Display Module and all the sensors and switches have been installed. This harness has been designed so that the various branches are long enough for most single seater and saloon cars. Occasionally, an individual branch may need to be extended or significantly shortened. If the standard harness is totally unsuitable for your vehicle, contact Stack for details of custom harnesses. Provided that you have chosen suitable locations for the switches, sensors and any external warning lights that you are installing, you should not need to extend any of the individual wires in the harness. Extender wires for connecting the fuel pressure and wheel speed sensors to the wiring harness are available in the following lengths:

- 700mm / 2'3" (ST918020)
- 1400mm / 4'7" (ST918021)
- 2100mm. / 6'11" (ST918022)

Trackside Infra-Red Lap Beacon (Optional, Std on ST8130M)

Press and hold Switch 1 and then press Switch 4 to reset the lap count and lap time to zero. The lap timer starts recording the time immediately.

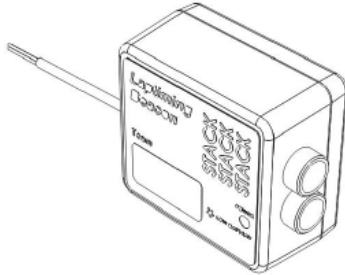

The ST544 trackside infra-red lap beacon should be located as follows:

- As near to the start-finish line as possible
- At the same height as the on-vehicle detector
- Level, so that it emits a horizontal beam
- It must be between 2 and 30 metres (6 and 100 feet) from the vehicle when the vehicle passes it

Avoid positioning it so that the sun is directly behind it when it is being used.

Where the unit is to be used for lengthy periods in very hot, sunny conditions, it should be protected by shading it from direct sunlight.

Do not allow water to be sprayed onto the transmitter lenses. During wet conditions, fit a protective shroud over the beacon.

Gear shift light

The external gear shift light comes on when the engine RPM exceeds a predefined value. See "Configuring the Display System" for information about setting this value.

If you purchased an optional ST539 Multi-Stage Shift Light, that will start to illuminate.

Chapter 4. Configuring the Display System

Configuration mode

You put the Dash-Logger into System Configuration Mode by pressing Switches 1 and 2 together. You then work through the configurable parameters in a preset sequence, pressing Switch 3 to display the next configurable parameter. The Stack banner, showing the model number, its version and release date, is displayed while holding Switches 1 and 2. This information will be required if you need to make a support call (see *Appendix D. Service and Support*).

Setting or resetting configuration values

Use Switch 1 to decrease the value being configured and Switch 2 to increase it. The rate at which the value increases or decreases itself increases while the switch is being held down.

Switching Alarms on or off

You can enable (switch on) or disable (switch off) each of the alarm warnings by pressing and holding Switch 1 and then pressing Switch 2.

Note that you might change the preset value of the parameter slightly while pressing both switches. This does not matter if you are switching the alarm warning off and, if necessary, you can correct the preset value after you switch it on again.

Lap timing sensor (Optional, Std on ST8130M)

The lap timing sensor is actuated by an infra-red beacon positioned at the side of the circuit. The sensor is fixed to a rigid bracket mounted at a convenient position on the outside of the vehicle where it is able to detect the signals from the beacon.

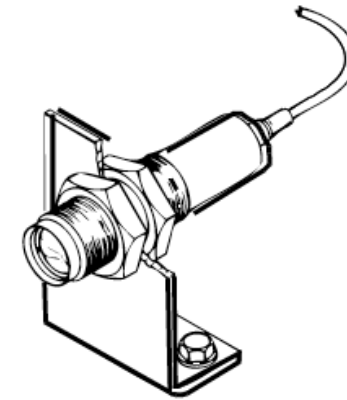

It is secured by two nuts (supplied) with an M18 x 1 mm thread.

This sensor must be positioned horizontally and square to the axis of the vehicle. In order to detect the signals from the beacon, it must be positioned outside the vehicle. It should, if possible, be positioned so that other vehicles that are being overtaken (or are overtaking) at the moment your vehicle passes the beacon do not block the signal.

Note that after detecting a signal, the system does not recognise any further signals from beacons for a period of ten seconds.

ST492 Technical Specification

Supply :	From ST8130 input
Output characteristics :	ST8130 compatible
Input impedance :	>50K Ohms
Operating temperature range :	-20 to +80 °C / -4 to 176 °F
Input threshold adjustment range :	-5 Volts to +12 Volts
Input hysteresis :	+/- 0.1 Volt
Maximum input frequency	2000 Hertz
Physical dimensions :	(mm) L 51, H 18, W 32 (in) L 2, H ¾, W 1¼
Weight :	50g / 2oz maximum
Vibration testing :	20 G, 50Hz to 2000Hz, 1 Octave/min for 12 hours

Fuel Tank Sender

Plug the adapter (ST918037) supplied in the sensor bag to the 4-way sure seal connector marked F.

Single-Wire Sender

If your vehicle is fitted with a single-wire sender (rheostat), remove the existing wire from it and connect the red (F) wire to it.

Two-Wire Sender

If your vehicle is fitted with a two-wire sender (potentiometer), remove the existing wires and fit the red (F) wire to one of the terminals. If there is no change in fuel level reading during calibration, fit the red wire to the other terminal.

System Configuration Mode

Summary of Switches:

Switch(es)	Functions
Switch 1	Decrease the alarm value of the parameter being displayed
Switch 2	Increase the alarm value of the parameter being displayed
Switches 1 & 2 together	Enable or disable an alarm for the parameter being displayed
Switch 3	Display the next configurable parameter
Switches 1 & 2 together	Enter Shift Light or Fuel Calibration mode
Switch 4	Exit configuration mode and return to normal operation mode

Menu Items

Examples of the displays for each of the configuration items are shown below.

Shift RPM:

```
EDIT SHIFT
Sw1 & 2 to calibrate
```

Refer to *Configuring the Multi-Stage Shift Light* later.

Low Fuel:

```
EDIT TEST
Low Fuel 10 L on
```

High Oil Temperature:

```
EDIT TEST
High Oil T 130C on
```

High Water Temperature:

```
EDIT TEST
High Water 105C on
```

Low Battery Voltage:

```
EDIT TEST
Low Batt 10.0 on
```

Low Fuel Pressure:

```
EDIT TEST
Low Fuel P 10.0 on
```

Low Oil Pressure:

```
EDIT TEST
Low Oil P 35.0 on
```

Fuel Level Calibration:

```
Swi & 2 to calibrate
Fuel Tank Sender
```

Refer to *Calibrating the Fuel Level* later.

Gate RPM:

```
EDIT TEST
Gate RPM 3000 on
```

Engine speed cylinders:

```
E.S. Cylinders 4
```

The plug, the smaller of the two connectors on the amplifier, is the connection to the sensor. Use the cable with a MSS connector at one end and two wires at the other to connect the amplifier to the speed sensor.

For a two wire sensor, connect sensor wires to the red and black wires on the cable.

For a single wire sensor, connect the sensor wire to the red wire on the cable.

Adjustment

Once the system has been fully wired power should be applied.

At this stage it is desirable to arrange for the sensor to generate a low frequency signal by spinning the wheel slowly. The red LED at the end of the amplifier should be seen to flash as each signal is received. If the frequency is higher than approximately 10 flashes/second the LED may only appear to dim, as the flashing is too fast for the eye to see.

If this does not happen (the LED is always on or off) it will be necessary to adjust the input sensitivity of the amplifier to match the sensor. This is accomplished by turning the small screw head, which is recessed, in the hole adjacent to the LED. This should be adjusted until the LED flashes consistently.

The operation should be checked at the lowest possible frequency, as this is the most likely speed for problems to occur.

Following these adjustments, correct operation can be verified by observing the LCD speedometer at a range of speeds.

Ideal application temperature range is 21-38°C (70-100°F). Initial application to surfaces at temperatures below 10°C (50°F) is not recommended because the adhesive becomes too firm to adhere readily.

To mount a sensor or housing on the vehicle

Take one of the supplied pieces of 'dual-lock' fastener, remove the adhesive backing and attach to the sensor or housing.

Take a second strip of the fastener and attach to the first piece by pushing them together firmly, ensuring correct alignment.

Remove the adhesive backing from the second strip of fastener and attach the sensor or housing to the vehicle in the desired position. Push against the fastener firmly to ensure maximum adhesion.

Do not try to separate the 2 strips of fastener immediately

The acrylic adhesive backing should be given 24 hours to achieve full bond strength.

If you require further fastener strip or have any comments, questions or recommendations regarding its use, please contact Stack or your nearest distributor.

Electrical

The amplifier connects into the ST8130 system via a four way Mini Sure Seal (MSS) socket, the larger of the two connectors on the amplifier. Use the extender cable with an MSS connector at each end to connect the amplifier to the WS input on the harness.

Wheel speed pulses:

```
W.S. Pulses/Rev  10
```

Refer to *Wheel Pulses and Circumferences* later.

Wheel circumference:

```
Wheel Circ  1000 mm
```

Refer to *Wheel Pulses and Circumferences* later.

Lap time pop-up duration:

```
EDIT POPUP
Lap Time    8.0  on
```

Set the time in seconds for which the Lap Time pop-up will be displayed when the vehicle passes the lap time beacon. The value changes in 0.4 second increments.

Start Logging RPM:

```
EDIT TEST
Log RPM     3000  on
```

Set the RPM at which the data recording is started.

- ! Recording always stops when the RPM has been at zero for more than five seconds.

Optional Parameters

The following parameters are only available on the ST8130M variant:

Predictive lap time bar width:

```

EDIT SCALE
Bar Width      0.45 s
  
```

Sets the width of the timeline bar either side of the centre. The normal setting is 0.45s meaning that time differences of up to 0.45s can be shown. If larger differences need to be displayed, increase this number. If smaller differences are expected, this setting can be reduced to provide a greater movement of the display.

Predictive lap time acceleration limit:

```

EDIT VALUE
Accel Limit    10.00G
  
```

Sets the maximum allowable acceleration in units of G. In order to reduce the effects of wheel-spin, this setting determines the maximum allowable acceleration of the wheel. If fitted to a non-driven wheel this can be left at the default value of 10.00G where it will have no affect, otherwise it should be set to a suitable value. In the wet this setting may need to be reduced.

Predictive lap time deceleration limit:

```

EDIT VALUE
Decel Limit    -10.00G
  
```

Sets the maximum allowable deceleration in units of G. In order to reduce the effects of wheel lock-up, this setting determines the maximum allowable braking deceleration of the wheel. This should be set to an appropriate value and reduced in wet conditions to ensure accuracy of the predicted lap time.

- ! For reasons of safety, NEVER connect the amplifier to an ABS speed sensor.

Installation**Mechanical**

The amplifier should be mounted, using the self-adhesive dual locking material supplied, in a position away from strong sources of heat and H.T. leads. It should be noted that this adhesive will not reach full strength for up to 24 hours. On one side of the module there is a small red LED and a potentiometer access hole. This potentiometer is used to alter the sensitivity and the LED is used to give visual confirmation of correct adjustment. Access to this part should therefore be considered when choosing a mounting position.

Using the 'Dual-lock' fastener with Stack sensors

This is a high opening force 'Velcro-type' fastener system with identical mating halves. It is intended to be used for semi-permanent fixing applications and is not intended for frequent dismantling.

For best performance, the following precautions should be taken:

Bond strength is dependent upon the amount of adhesive to surface contact development. Firm application pressure develops better adhesive contact and thus improves bond strength.

To obtain maximum adhesion, the bonding surfaces must be clean, dry and well unified. Typical surface cleaning solvents are isopropyl alcohol/water mixture (rubbing alcohol) or heptane. Use proper safety precautions when handling solvents.

This light should be ON when a target is in front of the sensor.

5. Undo the rear nut half a turn more.
6. Without rotating the sensor or rear nut, finger-tighten the front nut.
7. Lightly tighten the rear nut with a 13 mm AF spanner. Do NOT let the sensor rotate.

• *Do not over-tighten; one flat of the nut should be sufficient.*

Checks for correct installation and adjustment

1. Rotate the wheel and check that the built-in sensor light comes on for each target and goes off between each target.
2. Check that both the sensor and targets are rigidly mounted.
3. Check that the front nut or any fixings do not cover any part of the sensing end.

! *Check the gap between sensor and any of the targets is NOT less than 0.5 mm (3/16") so there is no risk of the sensor hitting the targets.*

Pulse Amplifier Interface (ST492-Option)

Introduction

This amplifier is designed to convert the output of an existing sensor, which generates a pulsed signal which is not compatible with the ST8130 system's channel input requirements. This incompatibility may be caused by insufficient voltage or lack of output current drive capability. The amplifier has negligible loading effect on the signal and includes the facility to adjust its sensitivity, so can be used with a wide variety of sensors.

Configuring the Multi-Stage Shift Light

The five LEDs of the ST539 Multi-Stage Shift Light can be made to illuminate in sequence with more coming on as the engine speed increases. For example, the first LED can be set to illuminate at 6200 RPM. Then both the first and second LEDs can be set to illuminate at 6400 RPM. An extra LED will illuminate in sequence at further RPM values until all five are lit.

Put the Display Module into System Configuration Mode by pressing Switches 1 and 2 together. Then work through the configurable parameters by pressing Switch 3 until the Edit Shift menu is displayed again.

Press Switches 1 and 2 together and the first Shift Light screen will be shown.

```

EDIT SHIFT LIGHT 1
Shift RPM 6200
  
```

Set the RPM value above which Shift Light 1 will illuminate. Use Switch 1 to decrease the value being configured and Switch 2 to increase it. The values change in 10 RPM increments.

! *If you have a single External Shift Light instead of the Multi-Stage Shift Light, it illuminates at the first shift point so Shift Light 1 is the only light which needs to be configured. Press Switch 4 to exit this menu early.*

Press Switch 3 to edit the second Shift Light RPM value.

```

EDIT SHIFT LIGHT 2
Shift RPM 6400
  
```

Continue pressing Switch 3 to edit the remaining Shift Light values.

When all the individual Shift Lights have been configured, the Edit Shift screen will be re-displayed.

Calibrating the Fuel Level

To calibrate the fuel level reading with the actual amount of fuel in the tank, you will need to start with a tank that contains the amount of fuel you require for its reserve and progressively fill it with known quantities of fuel. While filling the tank, you must use at least two and possibly as many as ten (the maximum permitted) calibration points to set values for accurate fuel level readings. More than five calibration points are recommended, with the first at zero (empty), the second at five litres, the third at ten litres and the remaining points divided equally across the amount of fuel still required to fill the tank completely.

Use the following procedure:

Set the Display System to configuration mode.

1. Decide how many calibration points and the amount of fuel for each that you are going to use. For example, to calibrate the readings for a 50 litre (10 gallon) tank for the following quantities, the following seven calibration points are suggested: 0, 5L (1gal), 10L (2gal), 20L (4gal), 30L (6gal), 40L (8gal), 50L (10gal).

For a 100L (20gal) tank, ten calibration points are suggested: 0, 5L (1gal), 10L (2gal), 20L (4gal), 30L (6gal), 40L (8gal), 55L (11gal), 70L (14gal), 85L (17gal), 100L (20gal).

Empty the tank so that it contains only the amount you require as its reserve. Use the fuel pump to empty the tank. Add the reserve fuel, for example, two litres (0.5 gal.).

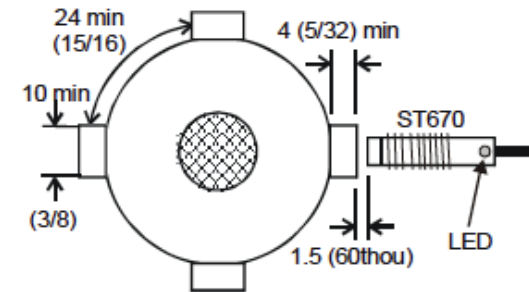

It is important that the sensor and targets are rigidly mounted so they do not move with vibration. The sensor bracket should have an 8 mm hole for the ST670 to pass through. Targets should be at least 10 mm (5/8") across and stand at least 4 mm (5/32") proud (Fig.1). Smaller targets can be used but this will reduce the range. Small aluminium, brass or copper targets will generally not work.

Nothing except the targets should come within 6 mm (1/4") of the end of the sensor. If the sensor mounting position is to be recessed, a hollow of 24 mm (15/16") diameter and at least 4 mm (5/32") deep should be allowed around the sensor.

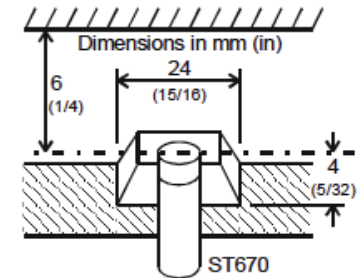

Sensor fitting and adjustment

1. Connect the sensor to the system and turn on the power.
2. Assemble the first (rear) nut onto the sensor.
3. Insert the sensor into the mounting bracket hole and fit the front nut.
4. Rotate the wheel and move the sensor slowly forward by undoing the rear nut counter-clockwise until the built-in light (LED) comes on for every target. That light is used to check that both the mechanical and electrical installations have been performed correctly.

Wheel speed sensor (ST670-Option)

The Display System is supplied with one Stack ST670 proximity sensor as a standard feature which must be fitted if the vehicle is to comply with the legal requirement for an onroad speedometer. This sensor is used to measure wheel speed in order to display the vehicle's speed in MPH or km/h. The sensor provides an electrical pulse to the system each time a ferrous object, such as a wheel bolt, passes near to the end of the sensor. When you configure the system, you will need to supply the circumference of the wheel and the number of ferrous objects that will be counted for each revolution of the wheel. If you are not sure whether the object you have chosen to use is ferrous, you can check it with a magnet. If there is no attraction, the object is not ferrous.

Fitting the wheel speed sensors

These sensors, when used for measuring vehicle speed, are best fitted to an undriven outside wheel. The sensor is triggered by a number of 'Targets' (see Sensor Targets). It is essential that these devices and their cables are positioned as far as possible from all sources of intense heat and from the ignition HT leads to avoid interference.

Sensor targets

The targets can be any suitable metallic object which passes within range of the sensor tip. Iron or mild steel targets are preferred as they give a stronger signal to the sensor. Aluminium, brass or copper targets give approximately one third of the sensing range which makes setting up the sensor difficult and may cause the speed signal to be unreliable.

You may wish to enter these values into the table below. If you ever have to return the unit for servicing, supplying the values from this table will allow Stack to automatically recalibrate the fuel display so that you will not have to repeat this process.

You should now drive to your local petrol (gas) station a fill the car on level ground in order to complete the calibration process.

To make the calibration process more efficient it is recommended that you have one person to operate the petrol (gas) pump & one person to operated the switches for the Dash.

Note: The petrol (gas) pumps may shut off, if the petrol delivery is interrupted for a time.

2. Select the Fuel Tank Sender calibration display. Hold Switch 1 down and press Switch 2. This gives a display similar to the following:

```
Tank Qty  0L
Reading 255
```

1. Use Switches 1 and 2 to change the Tank Qty value to zero if it is not already zero. Switch 1 decreases the value shown while Switch 2 increases it. Record the Tank Qty and the Reading value in the table below. When you have set the Tank Qty to the required value, press Switch 3 to store this value.

```
Sw1 = More
Sw4 = Quit
```

2. Press Switch 1 to continue to the next calibration point or Sw4 to abort the calibration process.

3. Fill the tank with a small, known amount of fuel, for example, five litres (one gallon). If the Reading value does not change, there is a problem with either the fuel sender or the wiring.
4. Wait for the Reading value to stabilise. This requires several seconds. While you are waiting for the Reading value to stabilise, use Switch 1 and Switch 2 to change the Tank Qty value to the amount of fuel now in the tank.
5. When the Reading value has stabilised, press Switch 3 to set this value.

```
Sw1 = More
Sw2 = Finished
```

6. Repeat steps 6 through 9 above for each calibration until the tank is full or you have performed at least two or as many as ten calibration operations.
7. Press Switch 2 (Finished) when you have completed calibrating the fuel level readings.

You can press Switch 4 to go to the cancel calibration mode, then Switch 1 to Cancel or Switch 2 to Continue with calibration.

```
Sw1 = Cancel
Sw2 = Continue
```

Cancelling the calibration leaves the original calibration set. The flowchart below summarises the steps in the calibration process:

- Do not over-tighten the sensor.
- The Fuel Pressure sensor must be connected to the A connector on the harness. A 1.4Mtr extender cable (ST918021) is supplied if the standard harness is too short.

Oil and Water Temperature Sensors

The Display System is supplied with two each of one of the following types of temperature sensor: Stack ST762 or ST764:

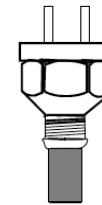

The ST762 temperature sensor has an M10 x 1 thread (EU versions).
The ST764 temperature sensor has two terminals and a 1/8" NPTF thread (UK/US version)

Each type of sensor can be used for monitoring both oil temperature and water temperature.

! *If you find that you have sensors with incorrect threads, please contact your distributor for advice.*

Fitting the temperature sensors

Mount each temperature sensor directly in the appropriate fluid line. Screw the sensor into a suitable mounting boss, so that its end lies in the middle of the flow of fluid.

- Position the sensors and their cables as far as possible from sources of intense heat and from the ignition HT leads.

- The sensor can be either screwed-in directly to the monitoring point or fitted remotely using suitable pressure hose to connect them to the monitoring point.

! *By fitting the sensor remotely, you will reduce the amount of vibration to which it is subjected and thereby extend its life.*

- Do not over-tighten the sensor.

Fuel Pressure Sensor

The ST8130P and ST8130M are supplied with one Stack ST747 pressure sensor with optional adapters to match the fuel pressure port of different types of engines.



Country Code	Thread Size
EU	M10 x 1
UK/US	1/8th NPTF
Option	1/8th BSPT

! *If you find that you have a sensor with an incorrect thread, please contact your Stack distributor for advice.*

Installing the pressure sensor

- Position the sensor and its cable as far as possible from all sources of intense heat and from the ignition HT leads.
- The sensor can be either screwed-in directly to the monitoring point or fitted remotely using suitable pressure hose to connect them to the monitoring point.

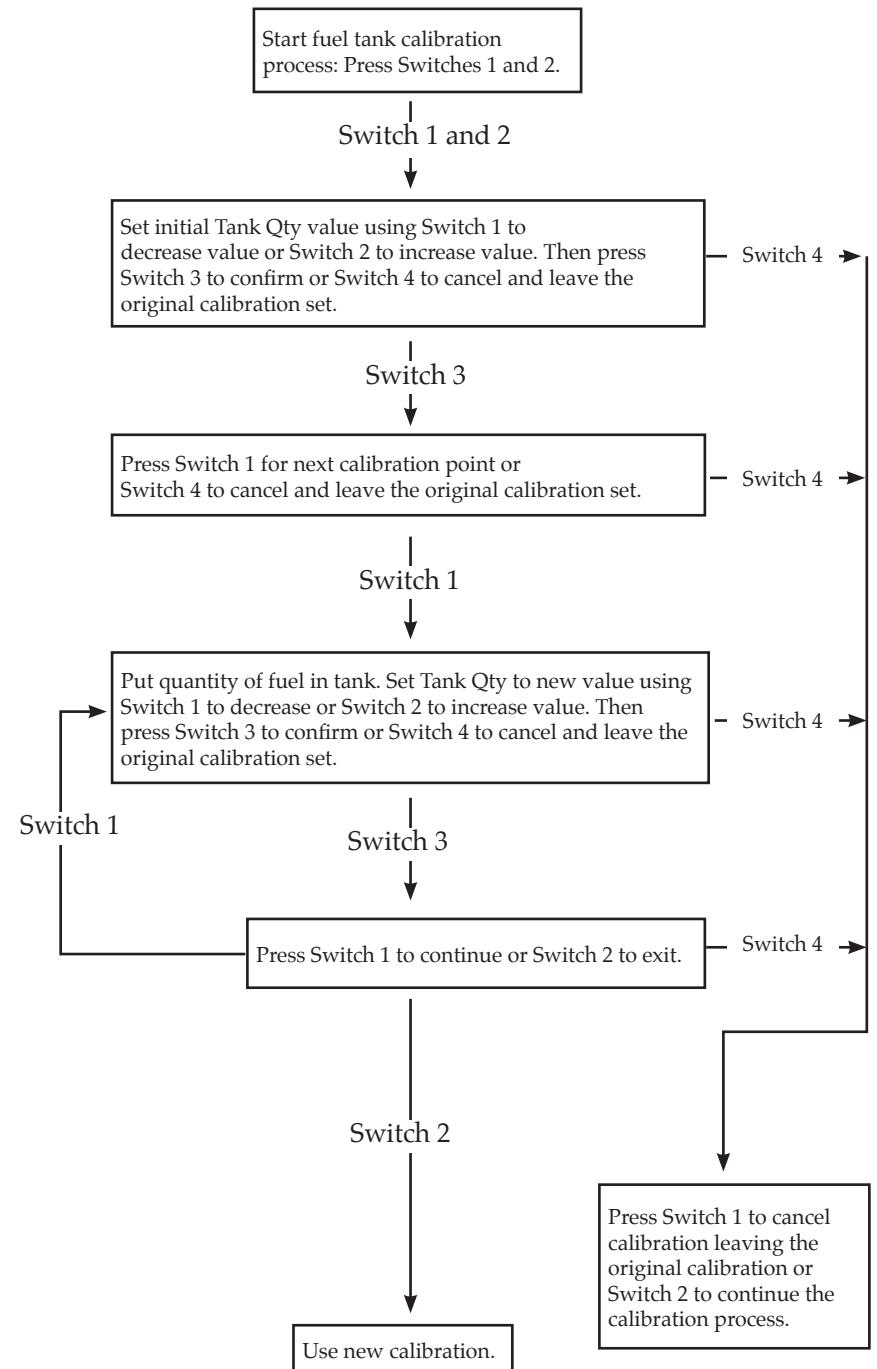

If the displayed reading values do not change by a significantly large amount from the empty to full condition, the fuel level sender in your vehicle may not be suitable for use with the ST8130 Road Car Display System. Check with your Stack dealer if this is the case.

When you wish to return to the normal display, press Switch 4.

Fuel Calibration Table

	Fuel Quantity	Reading
1		
2		
3		
4		
5		
6		
7		
8		
9		
10		

Wheel Pulses and Circumferences

Calculations for the Standard ST670 Wheel Sensor

You must supply a value for the wheel circumference that you obtain from one of the following calculations:

If the sensor is mounted on a wheel, set this value to the circumference of the wheel and set the number of pulses per revolution to the number of targets on the wheel.

- ! If the circumference is less than 500mm or 20.0 inches, double both this value and the number of pulses per

For systems which require a series resistor on the ES wire to limit interference from the high tension lead, a 10 KOhm ½ watt resistor must be connected directly to the terminals (which must be the screened type).

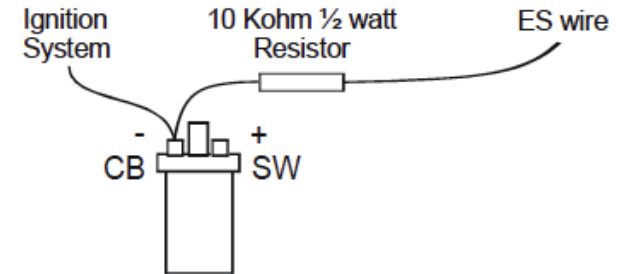

Oil Pressure Sensor

The ST8130 is supplied with one Stack ST747 pressure sensor with optional adapters to match the oil pressure port of different types of engines.



Country Code	Thread Size
EU	M10 x 1
UK/US	1/8th NPTF
Option	1/8th BSPT

- ! If you find that you have a sensor with an incorrect thread, please contact your Stack distributor for advice.

Installing the pressure sensors

- Position the sensor and its cable as far as possible from all sources of intense heat and from the ignition HT leads.

Ignition System	Connection Point
ECU	Direct to tachometer output
Coil and Points	Connect to the coil negative (low tension) terminal
HT coil lead	Use HT pick-up (ST697)

The following connections are shown in greater detail:

- Electronic ignition or ECU connection
- Standard contact breaker system
- Contact breaker series resistor connection

Electronic Ignition or ECU Connection

Connect the ES wire directly to the "Tacho" output of the electronic ignition or Engine Control Unit.

The signal can be either a 5 volt or 12 volt pulse.

- ! Some ECUs (eg, MoTeC M800) require a Pull-up resistor connected between the ES wire & +12v (battery positive). Resistor values between 470 & 4700 Ohms are required.

Standard contact breaker system

Connect the ES wire directly to the negative terminal on the coil.

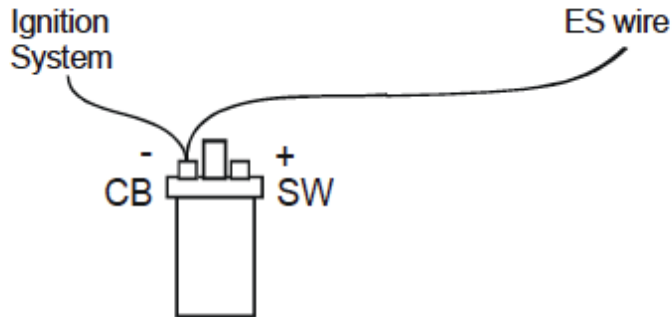

revolution. This will make the calculated speed and distance as accurate as possible.

If the sensor is mounted on a driveshaft or the propshaft, set the circumference to:

Actual wheel circumference ÷ differential ratio
-where the differential ratio is calculated as:
crownwheel (ring) teeth ÷ pinion teeth

- ! If the resulting value is less than 500mm or 20.0 inches, double both this value and the number of pulses per revolution. This is to make the calculated speed and distance as accurate as possible.

Set the number of pulses per revolution to the actual number of pulses per revolution of the shaft.

Examples for 9 pinion teeth & 41 crownwheel (ring) teeth:

UK/EU Differential ratio: $41 \div 9 = 4.55$
Pulses per revolution: 4
Tyre circumference: 1800mm
Circumference = $1800 \div 4.55 = 395\text{mm}$
Double the two values:
Wheel Cir (mm) = 790mm
W.S. Pulses/Rev = 8

US Differential ratio: $41 \div 9 = 4.55$
Pulses per revolution: 4
Tyre circumference: 70.9 inches
Circumference = $70.9 \div 4.55 = 15.6$ inches
Double the two values:
Wheel Cir(ins) = 31.2 inches
W.S. Pulses/Rev = 8

Calculations for the Optional ST492 Pulse Amplifier

You must supply a value for the wheel circumference that you obtain from one of the following calculations:

1. If you know the number of pulses generated for one mile (US version only):

$$63360 \div \text{pulses per mile} = \text{wheel circumference}$$

Set the number of pulses per rev to 1.

- *If the resulting circumference is less than 20.0 inches, double this value and set the number of pulses per rev to 2. This will make the calculated speed and distance as accurate as possible.*

Example:

Pulses per mile: 5000

$$\text{Circumference} = 63360 \div 5000 = 12.67 \text{ inches}$$

Double the two values:

$$\text{Wheel Circ (ins)} = 25.3 \text{ inches}$$

$$\text{W.S. Pulses/Rev} = 2$$

2. If you know the number of pulses generated for one kilometre (EU version only):

$$1000000 \div \text{pulses per km} = \text{wheel circumference}$$

Set the number of pulses per rev to 1.

2. If you know the number of pulses generated for one kilometre (EU version only):

$$1000000 \div \text{pulses per km} = \text{wheel circumference}$$

Set the number of pulses per rev to 1.

- *If the resulting circumference is less than 500mm, double this value and set the number of pulses per rev to 2. This is to make the calculated speed and distance as accurate as possible.*

3. If you know the number of pulses generated for one mile (UK version only):

$$1609344 \div \text{pulses per mile} = \text{wheel circumference}$$

Set the number of pulses per rev to 1.

- *If the resulting circumference is less than 500mm, double this value and set the number of pulses per rev to 2. This is to make the calculated speed and distance as accurate as possible.*

Warning lights

The Display Module has two built-in warning lights. The left-hand (amber) light is the fuel level warning light and the right-hand (red) light alerts the driver whenever an alarm has been triggered.

As an option, you can install additional external warning lights for gear shift and alarm warnings. The external warning lights should be installed in any position that is in the driver's direct line of vision, as they need to be visible at all times.

Stack Ltd can supply suitable external warning lights for installation in the dashboard (ST536/537) as well as shrouded versions that can be mounted on top of the dashboard (ST533/534).

! *If you are using your own warning lights, ensure that the bulb rating does not exceed 2 Watts; otherwise the Display Module will be damaged. If you need to use lamps greater than 2W, connect them to relays and use the output sockets from the Display Module to switch these relays.*

Engine Speed (RPM) Measurement

The engine speed (RPM) is measured by connecting the engine speed wire directly to the ignition system. A single wire, with the label ES, connects the Display System to the ignition system or low-tension side of the coil.

Connecting the Display System to the ignition system

The Display System can be connected to engines with a variety of ignition systems as shown in the table below:

Switches

The four switches are used to control the operation of the Display System.

The normal functions of the four switches are:

Switch	Functions
Switch 1	Show the peak values.
Switch 2	Clear an alarm or show the last alarm.
Switch 3	Change the display layer or clear an alarm.
Switch 4	Reset the trip distance to zero and start the lap timer. The trip distance is reset after each lap.
Switches 1 & 2	Enter Set up mode.
Switches 1 & 3	Change speed units to MPH or km/h & distance to miles or km
Switches 1 & 4	Reset the peak values and lap times.

You can install the switches in any convenient location.

When installing the switches, you should take account of the following considerations:

- The cable for each switch is approximately 400mm/16" in length from the 19-way military connector.
- It is important that the driver is able to reach Switch 3 easily in order to change the display and clear warning messages after alarms. This switch can be fitted on the steering wheel.
- When you configure the system, you use Switches 1 to 4 for selecting the parameters and setting their values. These switches should be installed so that you can reach them easily when you are viewing the digital display.

Example:

Pulses per mile: 5000

Circumference = $1609344 \div 5000 = 321.9\text{mm}$

Double the two values:

Wheel Cir (mm) = 644mm

W.S.Pulses/Rev = 2

4. If the pulses are coming from the wheel, ie, you know the number of pulses for each revolution of the wheel, enter the actual circumference and the number of pulses per revolution (see the following section)

Chapter 5. Installing the Display System

Who can install the Display System?

The Display System can be installed by anyone competent in fitting electrical and mechanical accessories to cars.

Tools needed to install the Display System

ST8130 with Standard ST670

No special tools other than normal workshop tools are needed.

ST8130 with Optional ST492

A trimmer tool or small flat jeweller's screwdriver (1.5mm or 1/16 inch blade) is required in order to adjust the pulse amplifier.

Preconfigured Display Systems

Use the instructions in the previous chapters to set up, operate and configure the ST8130 before installing it in the vehicle.

Custom Configured Display Systems

If you have purchased a Display System that has been custom configured for you, the system may include components not described in this manual. Refer to the additional instructions supplied with the system for such components.

This manual may refer to components not included in the system. You should ignore them.

Fitting the Display Module

The Display Module is fitted into a cut-out in the instrument panel/dashboard and secured using the two U-brackets at the rear. The dimensions for the cut-out are shown below. A full size template is supplied at the end of this manual.

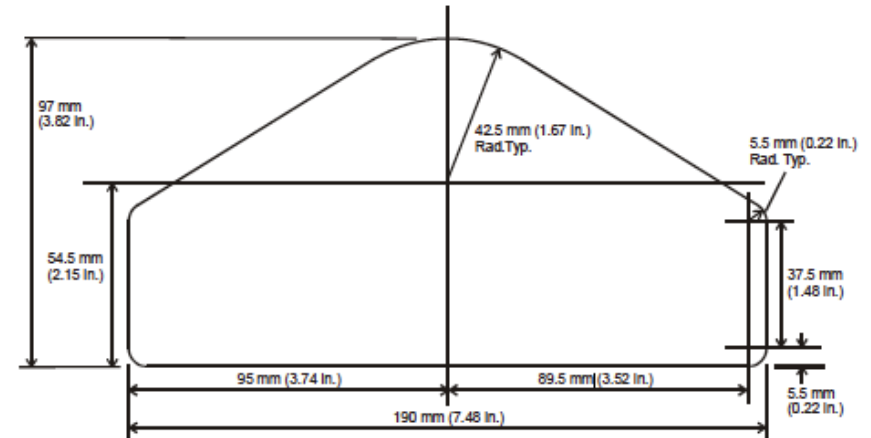

Positioning the Display Module

Ensure that there is sufficient space behind the cut-out to allow the wiring harness to be connected to the 19-way connector without any tight bends to the wiring near the connector.

The Display Module must be positioned on the dashboard so that the driver can see it, either over the steering wheel or through it.

The Display Module should be aligned so that the driver looks at it square or from slightly above or below.